

LOADING AND CLEARING THE 15E4-B SADDLE STAPLER

LOADING STAPLE CARTRIDGE

Open cover by pushing down on arrows and pulling cover apart.

If stapler head is in the "down" position, remove gear key from cover.

Disengage locking bar by lifting up. Remove staple cartridge.

Before inserting cartridge (50050), make sure that staples do not protrude past the "staple tear line." Staples are easily torn off at the tear line by pulling downward on staple belt.

Insert staple cartridge into the machine with staples facing forward. Cartridge must be placed flat on the plastic slide in the body of stapler and pushed firmly forward. Do Not allow cartridge to move backward once inserted into the stapler. Hold cartridge firmly in place and move locking bar (red grip) down until it snaps into groove on back of cartridge. Locking bar must be in place for the machine to operate.

NOTE: If cartridge is allowed to slide backwards, it must be removed from stapler, protruding staples torn off at staple tear line and then reinserted.

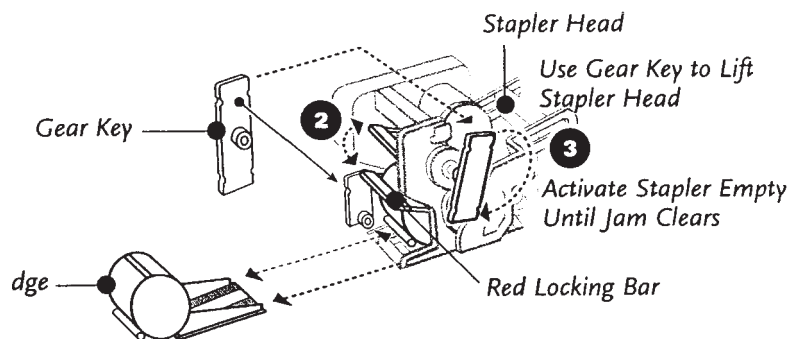

CLEARING A JAM

If stapler head is in the down position, remove gear key from cover.

Disengage red locking bar by lifting up. Remove staple cartridge.

Rotate gear at least one full turn until stapler head is in the up position.

Close cover.

Activate stapler 10 to 15 times to dislodge any problem staples.

Pull out an inch or more of staples and tear off at the stapler tear line by pulling downward on the staple belt. Re-insert cartridge.

Snap lock bar into place. Close cover and activate 3 or 4 times to eject first staple.